



CARBURETTOR TILLOTSON HW-27A



PHOTO OF ADJUSTING SIDE



PHOTO OF INLET SIDE

Manufacturer	TILLOTSON LTD.
Make	TILLOTSON
Model	HW-27A

SECTION VIEW

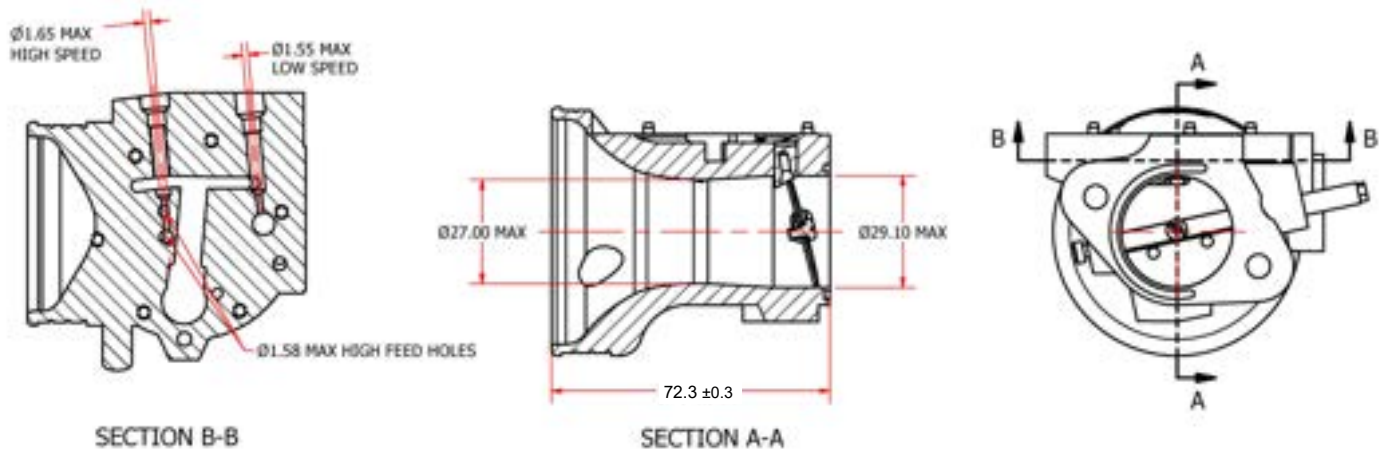

MARKING

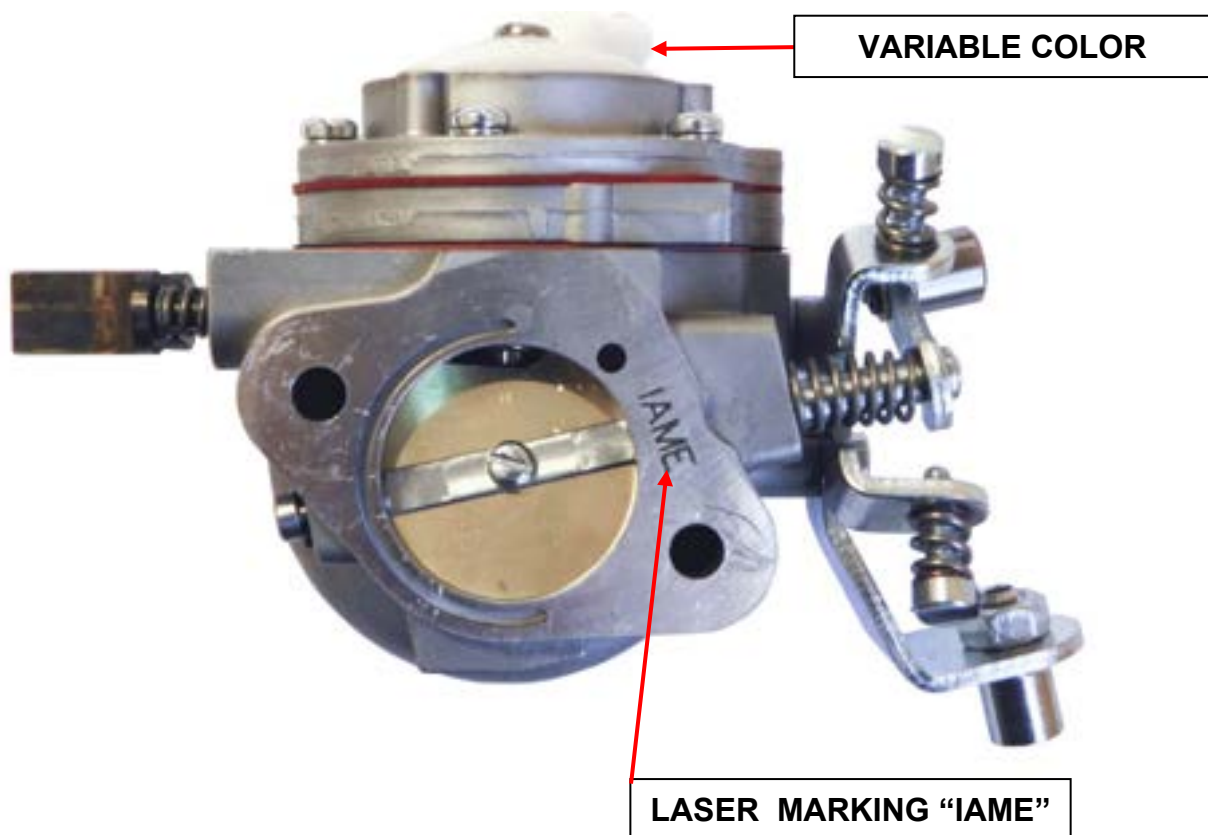

CARBURETTOR DESCRIPTION AND SKETCH OF PARTS

HW-27A

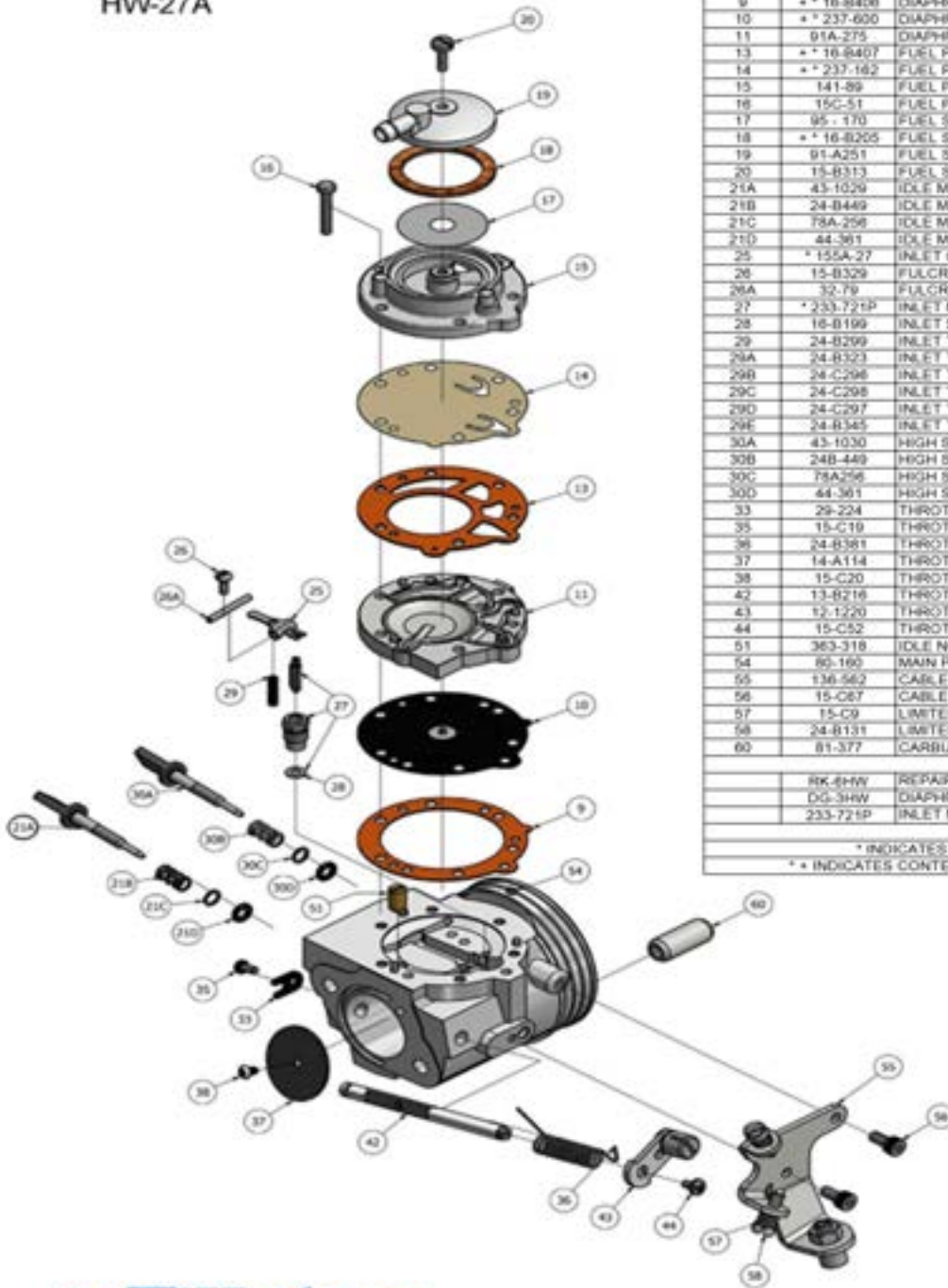

ITEM	PART NO	DESCRIPTION	QTY
9	* 16-8400	DIAPHRAGM GASKET (ORANGE)	1
10	* 233-600	DIAPHRAGM	1
11	91A-275	DIAPHRAGM COVER	1
13	* 16-8407	FUEL PUMP GASKET (ORANGE)	1
14	* 233-162	FUEL PUMP DIAPHRAGM	1
15	141-89	FUEL PUMP BODY	1
16	15C-51	FUEL PUMP BODY SCREW	6
17	95-170	FUEL STRAINER SCREEN	1
18	* 16-8205	FUEL STRAINER COVER GASKET	1
19	91-A251	FUEL STRAINER COVER	1
20	15-B313	FUEL STRAINER COVER RETAINING SCREW	1
21A	45-1029	IDLE MIXTURE SCREW	1
21B	24-B449	IDLE MIXTURE SCREW SPRING	1
21C	78A-256	IDLE MIXTURE SCREW WASHER	1
21D	44-361	IDLE MIXTURE SCREW PACKING	1
25	* 155A-27	INLET CONTROL LEVER	1
26	15-B329	FULCRUM LEVER SCREW	1
26A	32-79	FULCRUM LEVER PIN	1
27	* 233-721P	INLET NEEDLE & SEAT SET	1
28	16-8199	INLET SEAT GASKET	1
29	24-B299	INLET TENSION SPRING (STD 37 grams)	1
29A	24-B323	INLET TENSION SPRING (26 grams)	1
29B	24-C296	INLET TENSION SPRING (31 grams)	1
29C	24-C298	INLET TENSION SPRING (42 grams)	1
29D	24-C297	INLET TENSION SPRING (46 grams)	1
29E	24-B345	INLET TENSION SPRING (48 grams)	1
30A	43-1030	HIGH SPEED MIXTURE SCREW	1
30B	24B-449	HIGH SPEED MIXTURE SCREW SPRING	1
30C	78A256	HIGH SPEED MIXTURE SCREW WASHER	1
30D	44-361	HIGH SPEED MIXTURE SCREW PACKING	1
33	29-224	THROTTLE SHAFT CLIP	1
35	15-C19	THROTTLE SHAFT CLIP RETAINING SCREW	1
36	24-B381	THROTTLE RETURN SPRING	1
37	14-A114	THROTTLE SHUTTER	1
38	15-C20	THROTTLE SHUTTER SCREW	1
42	13-B216	THROTTLE SHAFT	1
43	12-1220	THROTTLE LEVER ASSEMBLY	1
44	15-C52	THROTTLE LEVER RETAINING SCREW	1
51	363-318	IDLE NOZZLE	1
54	60-160	MAIN H.L.U.	2
55	136-562	CABLE BRACKET	1
56	15-C67	CABLE BRACKET RETAINING SCREW	2
57	15-C9	LIMITER SCREW	2
58	24-B131	LIMITER SPRING	2
60	61-377	CARBURETTOR MOUNTING NUT	2
RK-6HW		REPAIR KIT	
DG-3HW		DIAPHRAGM & GASKET (STANDARD)	
233-721P		INLET NEEDLE & SEAT SET	

* INDICATES CONTENTS OF REPAIR KIT
 * * INDICATES CONTENTS OF DIAPHRAGM & GASKET SET



PARTS OF CARBURETTOR

REF.9 - P. N°16-B406
DIAPHRAGM GASKET (ORANGE COLOR)



Thickness = 0.5 ± 0.1 mm

REF.13 - P. N° 16-B407
PUMP DIAPHRAGM GASKET (ORANGE COLOR)



Thickness = 0.8 ± 0.1 mm

REF.10 - P. N°237-600
DIAPHRAGM



Thickness = 0.13 ± 0.07 mm

REF.14 - P. N°237-162
PUMP DIAPHRAGM

ALTERNATIVE



Thickness = 0.10 ± 0.063 mm

REF.11 - P. N° 91-A275
DIAPHRAGM COVER



Thickness = 6.75 ± 0.15 mm

REF.15 - P. N° 141-89
PUMP COVER



Thickness = 12.5 ± 0.15 mm

REF.37 - P. N° 14-A114
THROTTLE SHUTTER

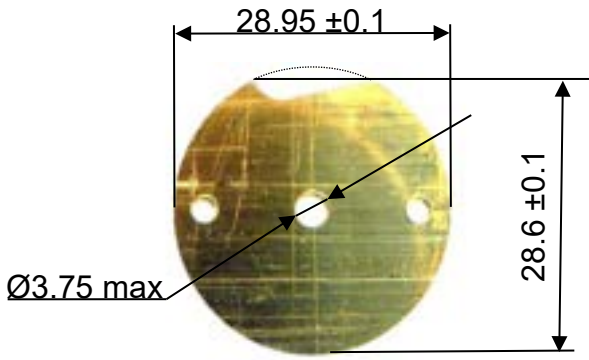

Thickness = 0.81 ± 0.1 mm

REF.27 - P. N° 233-721P
SEAT + NEEDLE

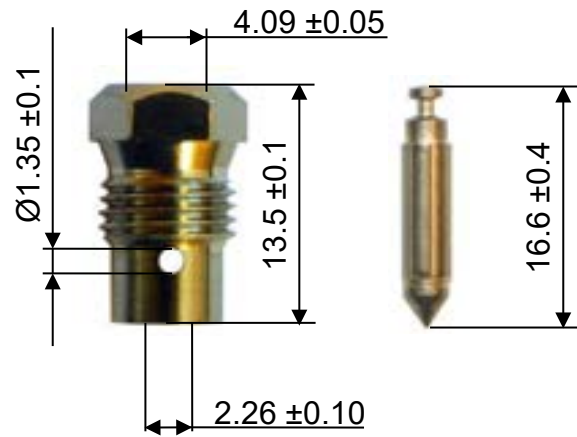

REF.21A - P. N° 43-1029
NEEDLE LOW SPEED



REF.30A - P. N° 43-1030
NEEDLE HIGH SPEED



ALTERNATIVE THROTTLE SHUTTER
(made from production tooling)

REF.37 - P. N° 14-A114

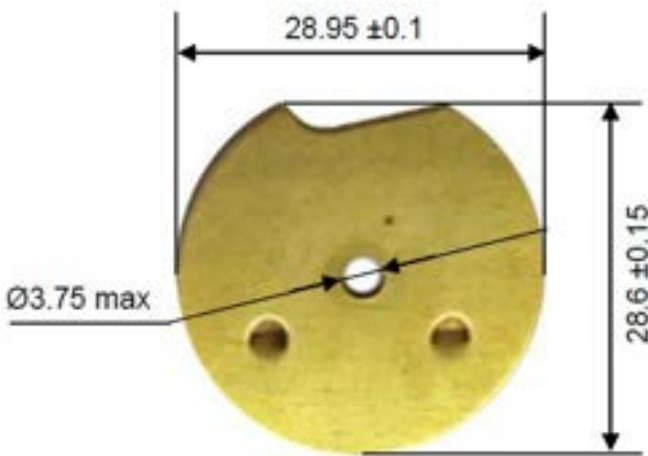

Thickness = 0.81 ± 0.1 mm

ALTERNATIVE FUEL NEEDLE

REF.27 - P. N° 233-721P



HOLE FOR CARBURETTOR SEALING

The carburettor can have this hole for sealing.

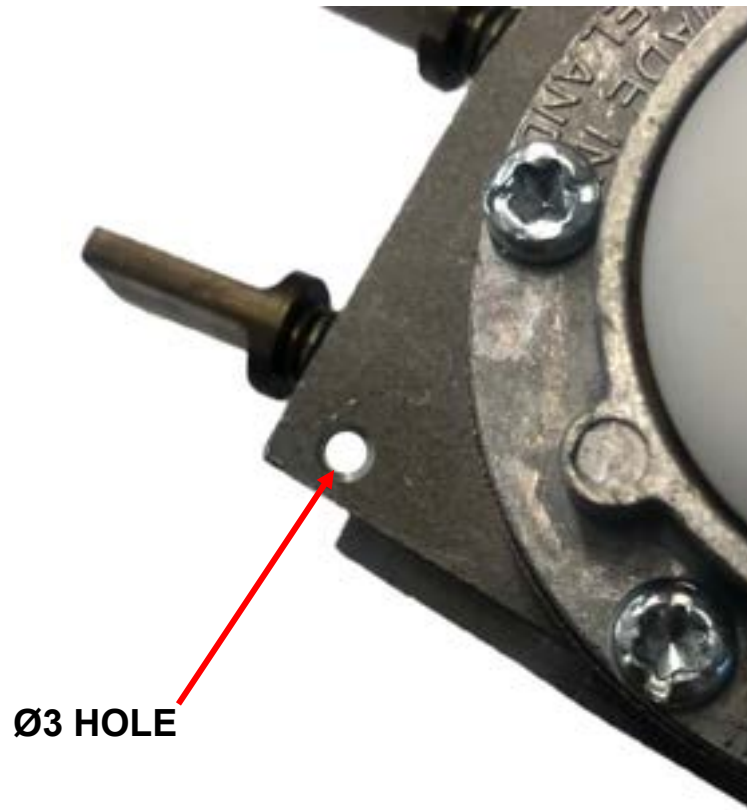

ATOMIZER - HEIGHT LIMITS AND CHECKING TOOL

